

Clamping force	240 kN
Shuttle stroke	700 mm
Dry cycle	3,2 sec

TECHNICAL DATA

Available in **single** station,
from monolayer to 6 layers configuration

BOTTLE DIMENSIONS AND HEAD CAVITIES

CAV	CD	W
2	330	290
3	215	175
4	160	130
5	125	100
6	105	85
7	90	75
8	75	60
9	70	55
10	60	50

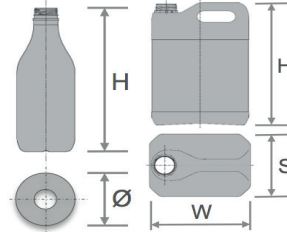
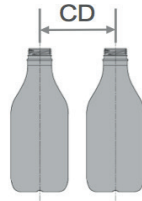

W=max bottle width

S	maximum bottle thickness	mm 140
Ø	maximum bottle diameter	mm 140
H	maximum bottle height	mm 325

MOULD DIMENSIONS

Max mould width	A	mm	695
Max mould height	B*	mm	450
Half mould depth	C	mm	175
Daylight opening	E	mm	200
Carriage opening	D	mm	550

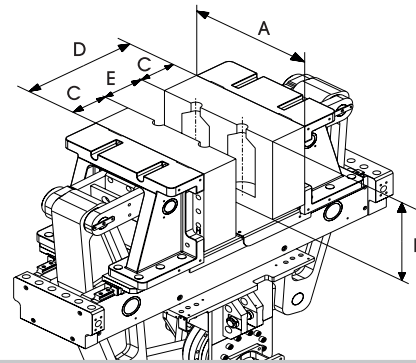

*with mould not exceeding above top of platen

EXTRUDER PLASTICIZATION CAPACITY

Screw diameter / L:D ratio	mm	40/26	50/26	60/26	70/26	80/26	90/26	100/26
Maximum extruder output *	kg/h	45	65	85	115	180	215	325
Recommended extruder output **	kg/h	34	49	65	87	137	163	247

* Maximum output is to be considered for 100% rpm with HDPE with HLMFI >15, 100% virgin pellets.

** Recommended output is at 80% of the maximum output with HDPE 70% virgin pellets + 30% regrind.

CONSUMPTION ESTIMATED UTILITIES DATA

Water operating pressure	bar	3 ÷ 5
Recommended water ΔP	bar	≤ 1,5
Air operating pressure	bar	8 ÷ 10
Air flow requirement std. blowing	NI/min	4.500 ÷ 4.700
Estimate power consumption	kW/kg	mono 0,27 coex 0,31

DIMENSIONS

W	mm	2.200
L	mm	4.800
H	mm	3.600

